

NOTES

1	Entry ramp covered with rubble.
2	Post-holes in floor on both sides of doorway.
3	Walls badly damaged, especially at door jambs.
4	Floor very roughly cut.
5	Pit in floor with sarcophagus lid.
6	Unfinished cutting.
7	Modern retaining wall.

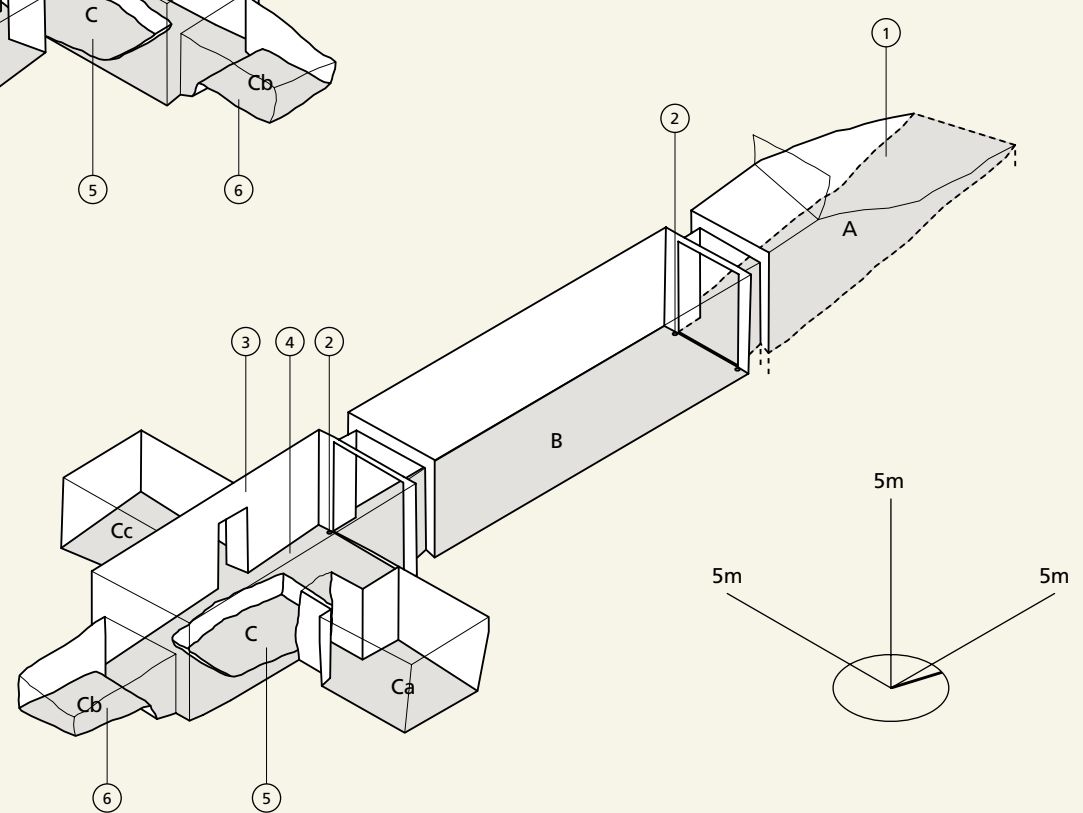
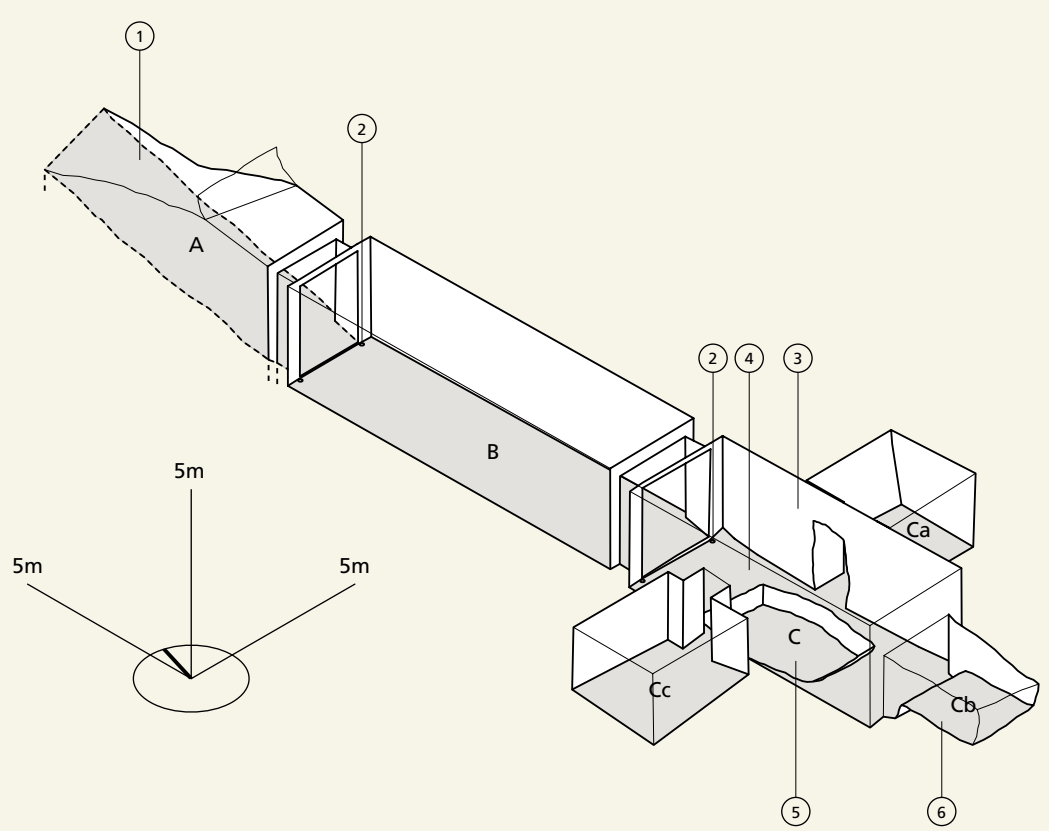
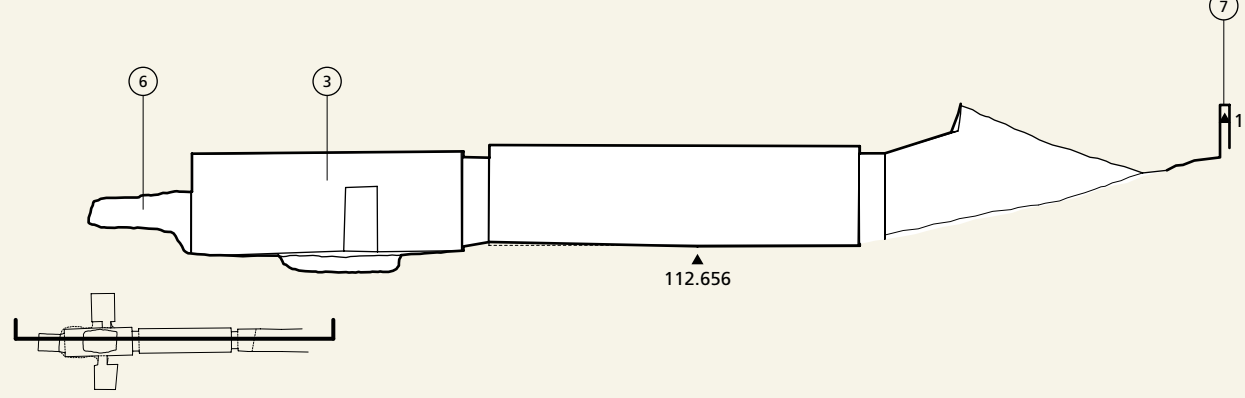
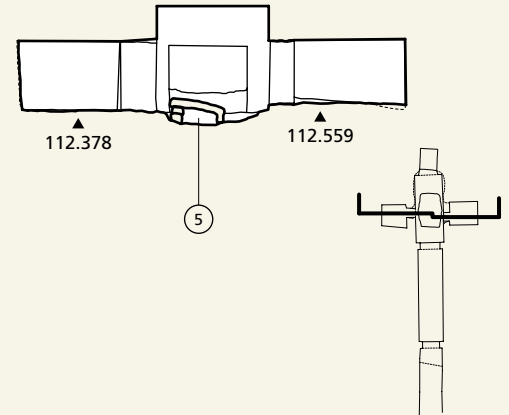
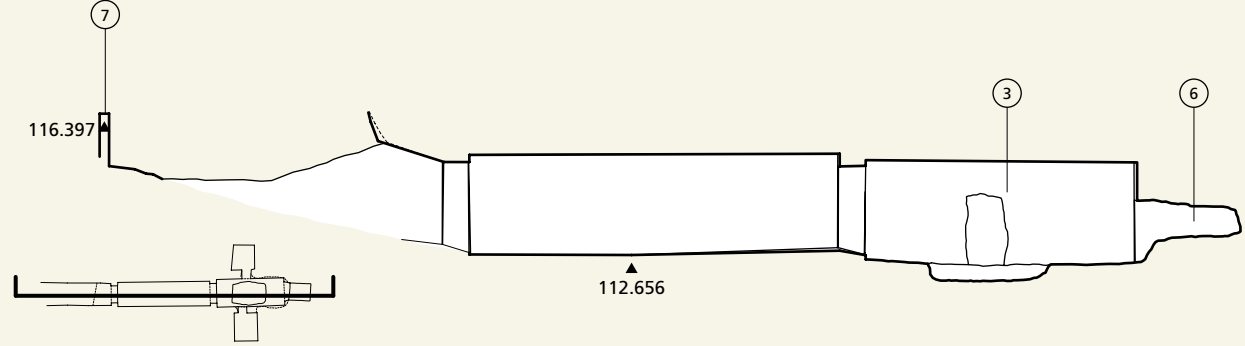
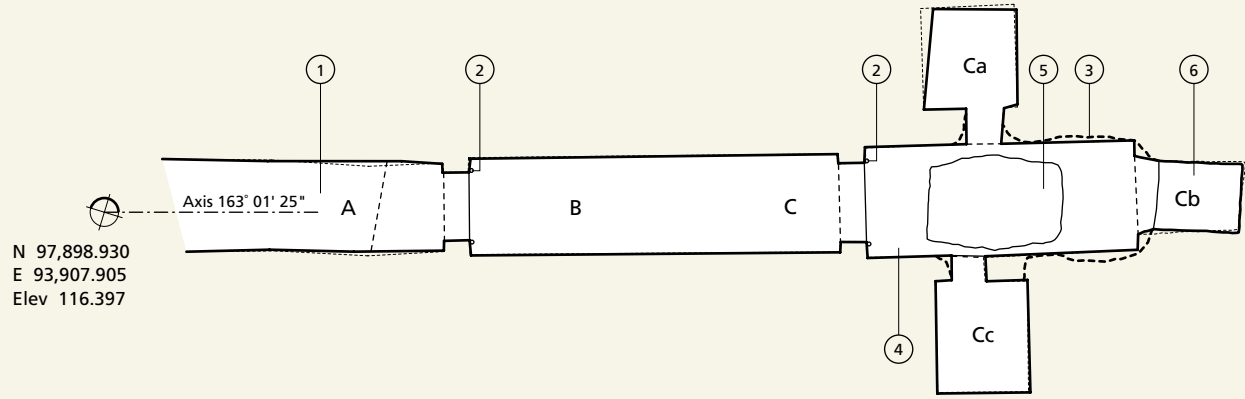
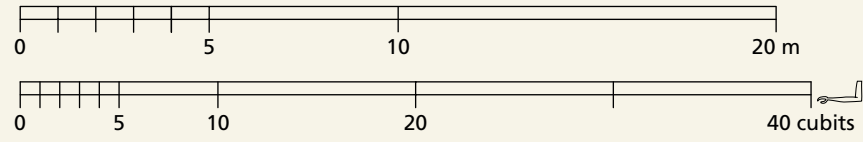
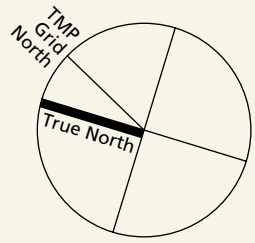

Courtesy of the Getty Conservation Institute and the Ministry of Tourism and Antiquities.